



<i>Title:</i>	REMOTE METERING SYSTEM APPLICATION (AMR)				
		<i>Project:</i>	AMR	<i>Code:</i>	ANB005_AMR_1_1.pdf
				<i>Date:</i>	Milan, 21 June 2005
<i>Status:</i>	design	<i>Approved:</i>	Guido Moiraghi	<i>Page:</i>	1 di 5

SUMMARY

1. AMR application and solution: the 169 MHz new band.
2. The operative frequency: criteria of choice.
3. Transponder: the meter radio system.
4. Preliminary block diagram using STE solution.

<i>Title:</i>	REMOTE METERING SYSTEM APPLICATION (AMR)				
		<i>Project:</i>	AMR	<i>Code:</i>	ANB005_AMR_1_1.pdf
				<i>Date:</i>	Milan, 21 June 2005
<i>Status:</i>	design	<i>Approved:</i>	Guido Moiraghi	<i>Page:</i>	2 di 5

Milano, 14 Giugno 2005

1. The 169 MHz new band: AMR application and solution.

The AMR system is conceptually based on the 3 following "elements" implementation:

- a) The radio system embedded into the "meter" unit (the "transponder") supplied by a battery package, including a data transceiver, a calibrated antenna and a microcontroller.
- b) An operator's portable unit (PDA) to display the info collected by the "transponders": the PDA is based on a data transceiver interfaced to a notebook and it is provided of keyboard and LCD display.
- c) A central station as "central data collector unit" placed in the operative control center: through the "central data collector unit" it is possible to monitor the "PDA" unit; it is also possible to upload "PDA" instruction and display all collected datas to be computed in according to the specific tasks assigned to the system.

The system, in the basic layout definition, is composed by different and separate stages: it is very important to understand that those stages, which are including both software and hardware engineering and development, must be conceptually integrated and that means the project have to consider the engineering of the "transponder" (as mentioned) but also the "PDA" unit which includes the RF interface and, last but not least, the master station provided of a database and all the necessary operative programs to provide specific functions in according to system specification. All that surrounded by a correct RF software protocol which guarantees the functions to adapt the system to the wireless communication requirements.

<i>Title:</i>	REMOTE METERING SYSTEM APPLICATION (AMR)				
		<i>Project:</i>	AMR	<i>Code:</i>	ANB005_AMR_1_1.pdf
				<i>Date:</i>	Milan, 21 June 2005
<i>Status:</i>	design	<i>Approved:</i>	Guido Moiraghi	<i>Page:</i>	3 di 5

2. The operative frequency: criteria of choice.

Obviously the frequency employed must be selected within the "SRD" (Short Range Devices) *License exempt (ERC-REC 70/03)* assigned bands: in this specific case we can consider the use of the 433 MHz and the 868 MHz bands.

Through a recent (March 2005) "CEPT" decision, a new band on 169 MHz has been assigned and some of the channels provided on this band are specifically reserved for "AMR" (Automatic Meter Reading) service utilities (see ECC/DEC/(05)02 – decides 3c, page 5).

The use of this VHF band gives several benefits on the wireless "AMR" utilities:

- a) Better radio-waves indoor propagation.
- b) High selectivity and sensitivity of receiver units: the assigned channels are provided of 12.5 KHz channel spacing which guarantee -125 dBm Rx sensitivity (20 dB more than the sensitivity of actual systems on the market) as an achievable target.
- c) Less power consumption compared to similar system actually in production.
- d) Less costs in according to lower components' specification requirements (as in example Xtal's specs).

3. Transponder: the Meter Radio System.

A simple block diagram of a "transponder" unit is displayed in figure 1.

The microcontroller controls the functions: the data received from the meter are stored in the memory of the "transponder" which controls the activity periods and "Sleep" time to minimize the battery consumption.

The "clock" is programmed to activate the system's operation in according to fixed period of communication to reduce furtherly the battery consumption of the system.

The data exchange between the "transponder" and the system is initialized by the reception of a data-request from the "PDA" held by the system operator.

Many other additional tasks may be implemented, as the option to send commands to the meter (i.e. the system's locking or temporary / permanent service suspension).

During data exchange between the "transponder" and the "PDA" unit, the "PDA" 's clock (more accurate than the "transponder" Xtal) provides time alignment and correction.

<i>Title:</i>	REMOTE METERING SYSTEM APPLICATION (AMR)				
		<i>Project:</i>	AMR	<i>Code:</i>	ANB005_AMR_1_1.pdf
				<i>Date:</i>	Milan, 21 June 2005
<i>Status:</i>	design	<i>Approved:</i>	Guido Moiraghi	<i>Page:</i>	4 di 5

3.1 Fig. 1: "transponder" block diagram.

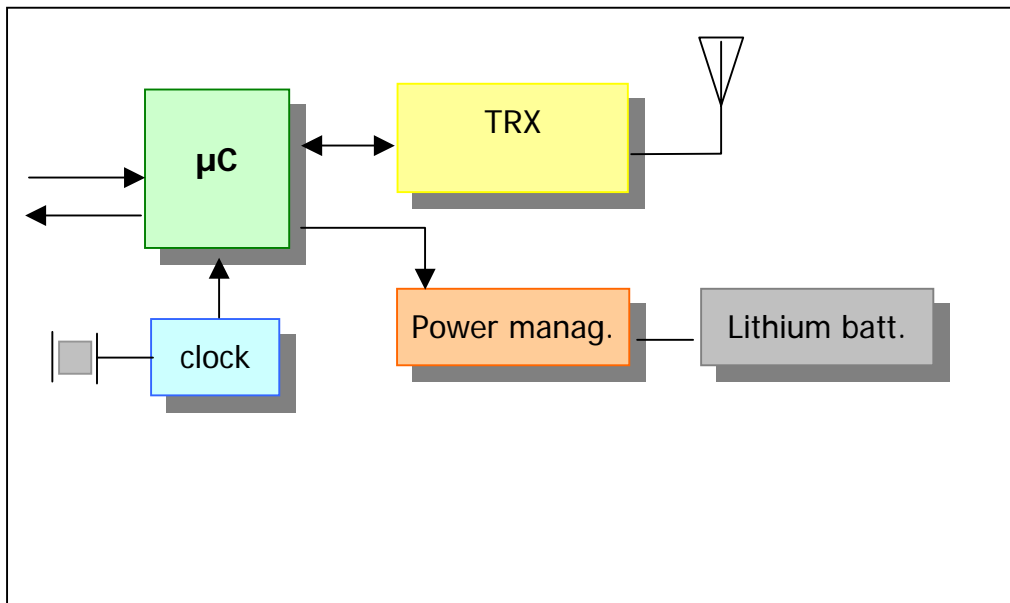

<i>Title:</i>	REMOTE METERING SYSTEM APPLICATION (AMR)				
		<i>Project:</i>	AMR	<i>Code:</i>	ANB005_AMR_1_1.pdf
				<i>Date:</i>	Milan, 21 June 2005
<i>Status:</i>	design	<i>Approved:</i>	Guido Moiraghi	<i>Page:</i>	5 di 5

4. Conclusion.

The used microcontroller must have specific characteristics optimized to provide low power consumption and "sleep" mode operation.

The memory stack which is in charge to storage the data (the metering data collection) must have the correct size in according to the system implementation: as an example shall be provided of larger memory in case the system must provide output of additional informations as date, time and other similar options.

The battery pack has to be sized in according to system's tasks required by the application: as mentioned above the system may be provided of much different options and functionalities therefore the battery specification have to be implemented in relation to the specific use for which the system is designed to operate:

Tx power output.

Period and metering service timetable chart.

Frequency of metering service.

And other specific tasks.

A Lithium-thionile 3.6 V battery, R6-AA size with 2.2A/h capacitance is able to guarantee up to 7 Years authonomy of the system.

STE Team
Engineering department